

Large-scale data analysis system (LSC) for open-use HSC data

Hisanori Furusawa

for ADC/Subaru Telescope open-use support team
2019.11.17 Subaru Users Meeting

1. Background and Aim

- Increasing demands of large volume data processing
 - HSC Open-use + HSC-SSP
- No optimal platform to process HSC data

The Multi-wavelength Data Analysis System (MDAS)

[日本語\(Japanese\)](#)

Introduction

■ The Multi-wavelength Data Analysis System

The Astronomy Data Center (ADC) operates the Multi-wavelength Data Analysis System (MDAS) which is an open-use computing system. This system is constructed to analyze astronomical data of various wavelengths. It provides over one hundred pieces of software and supports astronomy data reduction and analysis observed by various telescopes.

MDAS@ADC

Interactive nodes for short-lived processes

Up to 16 core batch jobs



Hanaco@HSC

Small Linux box

(32 core, 256GB, 100TB)

→ We are developing a new cluster system (LSC) to improve support

2. LSC: Target operation and users

- Open-use facility cooperated by Astronomy Data Center (ADC) and Subaru Telescope
- Initial operation focused on HSC data analysis
 - HSC-SSP data production (~1-2 times a year)
 - HSC open-use observers (approved by the observatory)
 - General HSC users (incl. archive users)
- In the future, may be extended to more general purposes and more strategic use

3. The current state of the LSC system

- Aim to extend up to ~2000 cores in 5yrs (budget not secured)
- 5PB fast shared filesystem (Spectrum Scale)
- 280 core computing nodes
 - Being used for initial users
 - 2-3 users at maximum
- 1,056 core CfCA cluster
 - borrowed for SSP data production

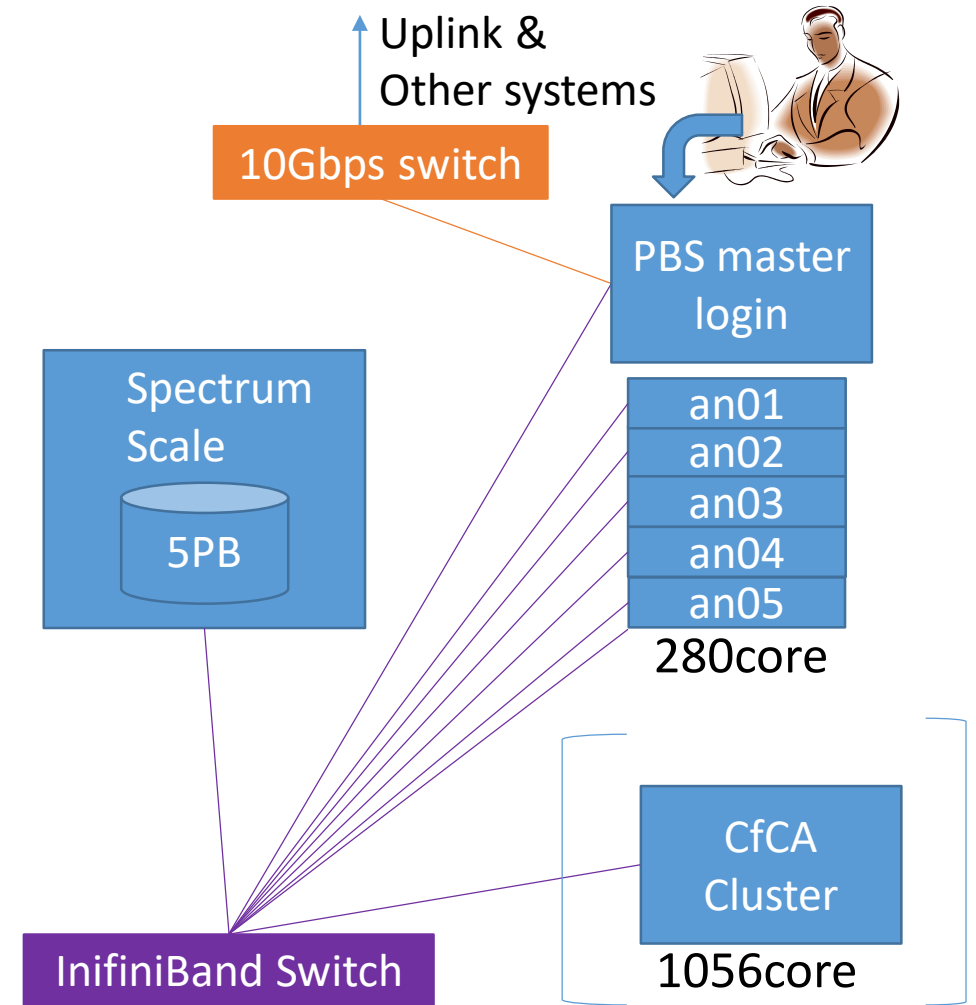

4. System upgrade – By the end of FY2019

- Actually approaching close to 2000 cores
(budget in next FY's not secured)
- Enable to host various jobs
 - SSP, ~5 Open-use users, Archive users
 - Openuse processing services etc.
- CfCA cluster can be used for other HSC work

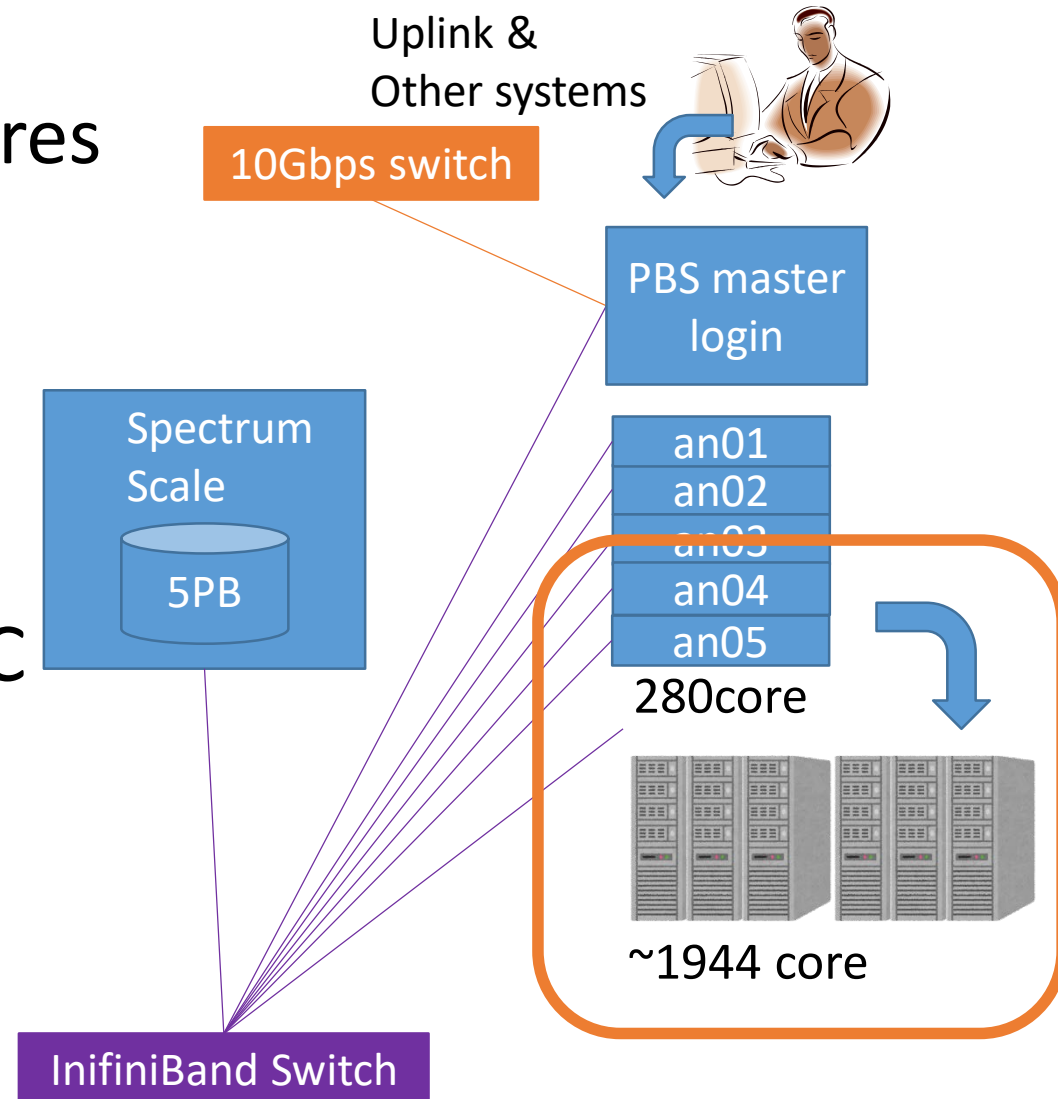

Cost effective effort?

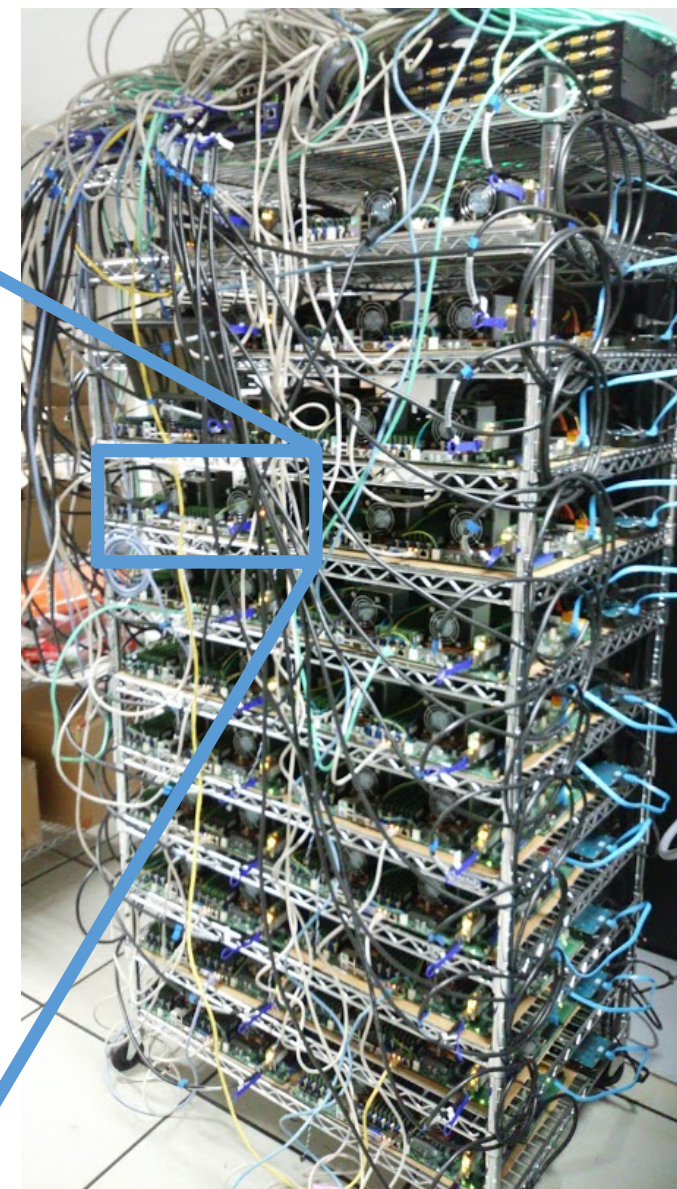
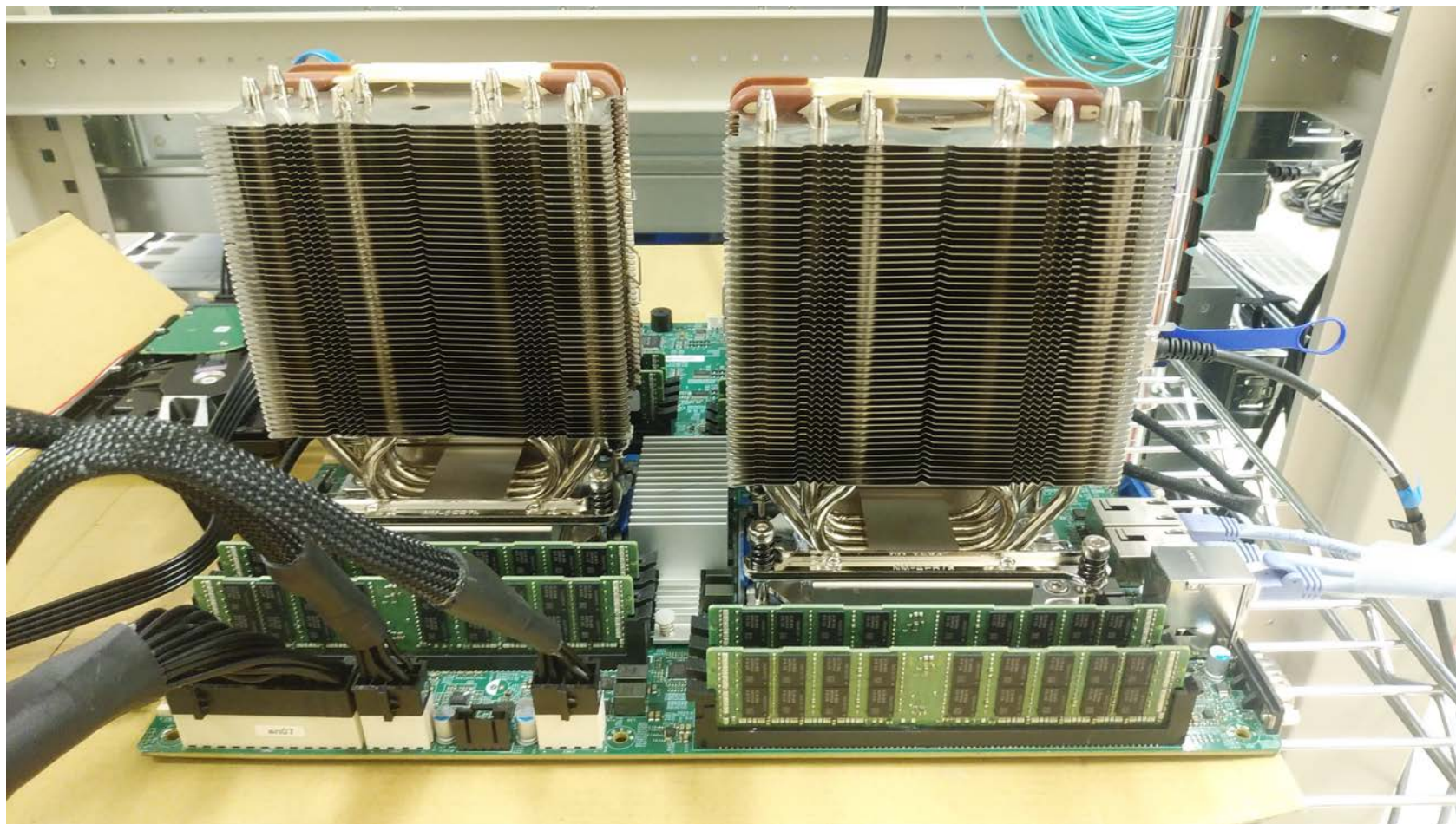

5. Operation Updates

- **We have started to accept users**
 - Application announcement to S19B-PIs in last September
 - 7 users registered to date
 - **280 cores** are allocated to users
 - All the jobs are executed by a **batch job system** (PBS Pro.)
- Built test computers for procurement of additional nodes
 - 10% slower than the existing Xeon nodes, but faster x2 than old cluster.

6. Queue and job control

- Resources assigned based on job queues with different priority
- Open-use observers assigned relatively-high priority for 1 year

Queue Name		N.Core	Job Lifetime	Term	Priority
Qh	SSP	~1000	>2months	x 2/ year	High
qm	Open-use HSC Observers	112	15days	1 year	Mid
ql	General users	28	15days	-	Low
Test	test	4	10min	-	High

Parameters are for initial operation

7. MDAS for Interactive Work

- LSC is a sub-component of MDAS, **dedicated for intensive processing**
- Use MDAS interactive nodes for post-processing work including scientific analyses, writing papers

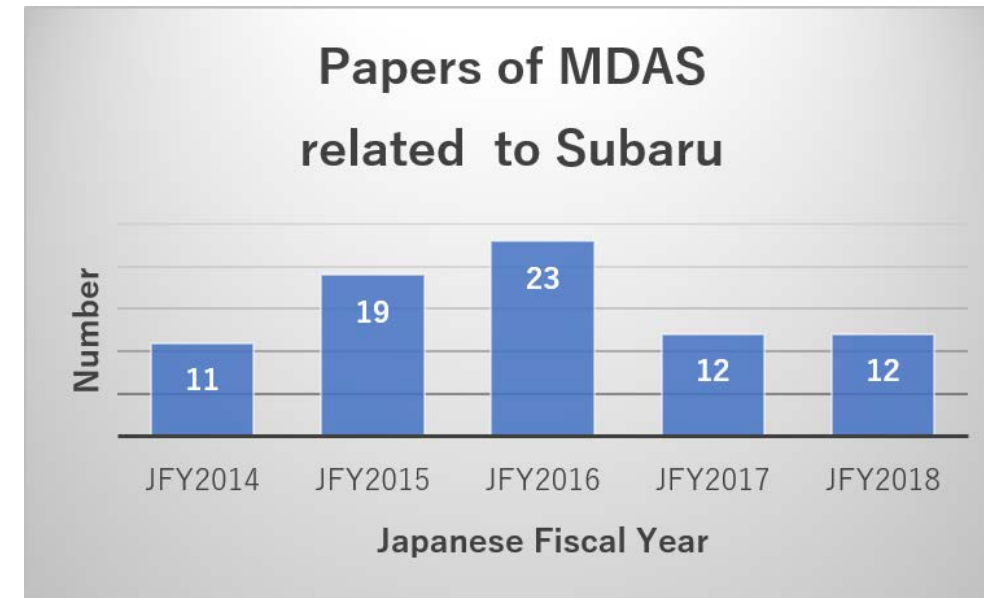
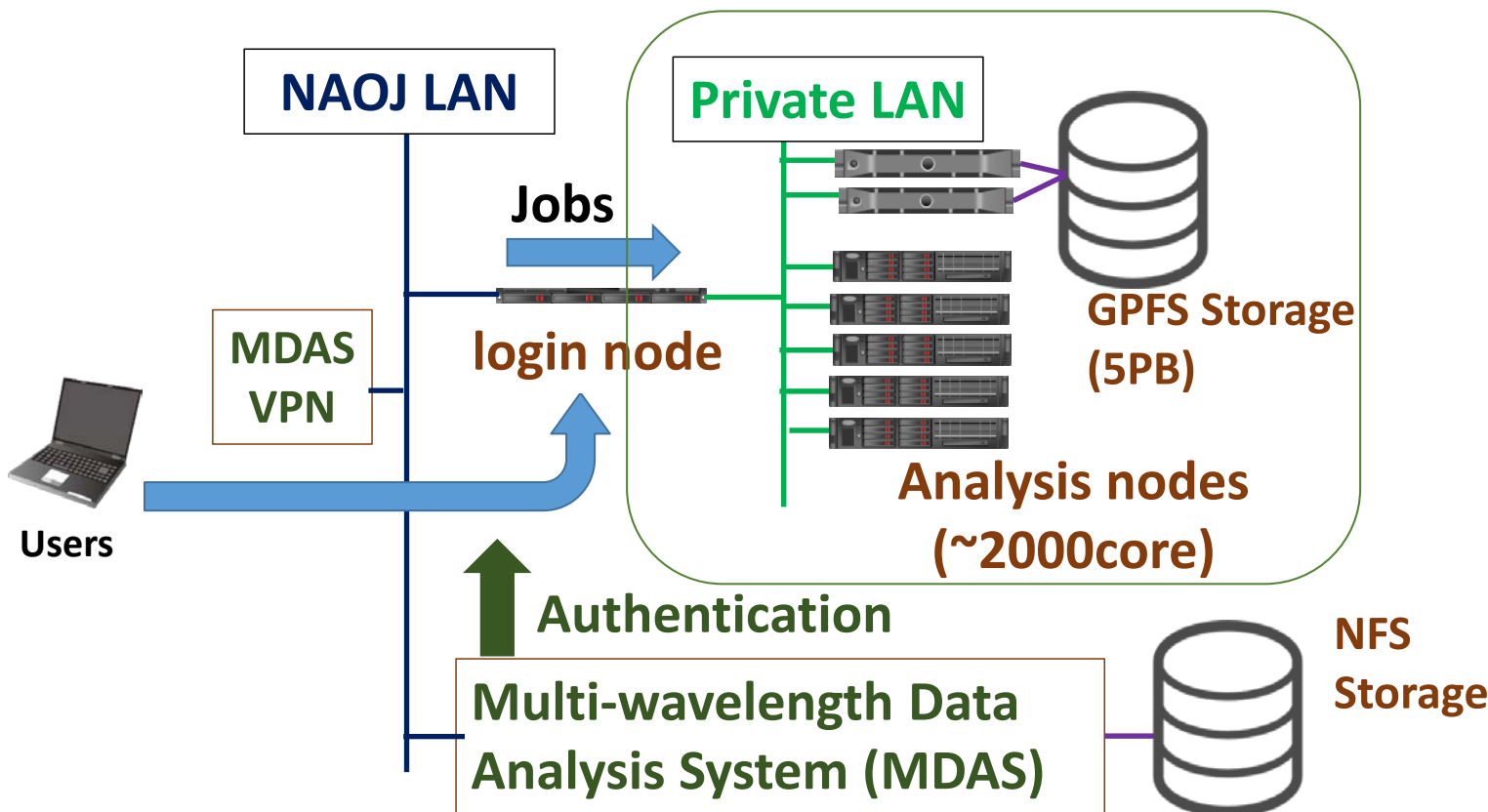

77 papers from MDAS
incl. 13 papers based on HSC data

8. Application Procedure

1. The observatory: announce to PI's after approval
 - Next one will come out in 2 months
 - **General (archive) users** will be accepted by early next fiscal year
2. PI: **submit PI/Col info + when to use** to the observatory
3. PI/Col: register for **MDAS account** at ADC
 - ✂ Export control procedure (Gaihi-Hantei) may take long time for researchers located in foreign institutes
4. PI: submit **who and when to use to ADC**

Summary

- ADC and Subaru Telescope cooperates LSC
- Analysis nodes are being added
- User registration is open to the open-use observers
- Preparing to accept general users by early next fiscal year

Web page and contact:

- <https://www.adc.nao.ac.jp/LSC> (System overview)
- daikibo_at_naoj.org (Observatory user registration)
- lsc-consult_at_ana.nao.ac.jp (ADC system operation)